



## Features:

- Three phase power regulator, auto phase detection
- Soft start function to protect SCR and load against surge current
- Integrated display with various LED indicator for status and error display
- Integrated heatsink and fans with temperature detection
- Maximum and minimum output configurable
- Rated load voltage 200~480Vac 50/60HZ
- Power supply for SCR to work is 220Vac, 24VDC optional
- Input, 0-10Vdc, 4-20mA, 0-5Vdc, 1-5Vdc, 2-10Vdc, 0-20mA, 0-10mA
- Rated current options, 40 amps, 60 amps, 75 amps, 100 amps.
- This SCR only compatible with resistive load
- SCR is compatible with both Delta and Star configuration
- In a 3 phase 4 wire system with neutral wire, the neutral wire can't be connected to the system, 3 phase should be balanced

## Technical Specifications

### Ordering Information

SCR-**1**-**2****3****4****5**-**6****7**

#### 1: Type of SCR power regulators

**7** 7 series SCR regulator (without alarm and RS-485 function)

#### 2: Load phase

**3** 3 phase load system

#### 3: Load current

**4** 40 amps 200~480Vac  
**6** 60 amps 200~480Vac  
**7** 75 amps 200~480Vac

#### 4: Power supply for the unit itself

**2** 220Vac  
**D** 12-24Vdc

#### 5: Input signal

**1** 0-10mA  
**2** 0-20mA  
**8** 4-20mA  
**5** 0-5Vdc (potentiometer)  
**6** 0-10Vdc  
**7** 1-5Vdc  
**3** 2-10Vdc

#### 6: Over temperature alarm (This option only available for SCR-6 and SCR-7)

**N** without alarm  
**M** with 1 alarm, relay output

#### 7: Communication (This option only available for SCR-6 and SCR-7)

**N** without communication  
**M** With RS-485 modbus RTU communication

Remark: **SCR-7-3128-NN**

SCR-7 series  
 3 phase 4 wire system  
 100 amps  
 Auxiliary power supply is 220Vac  
 Input signal: 4-20mA  
 With out alarm, without Modbus RS-485

### Important Notes

- SCR is compatible with both Delta and Star configuration
- This SCR only works for resistive load
- **In a star configuration, the neutral wire can not be connected to system**
- Example on how to choose correct model based on your specific requirements

Example 1: to choose correct SCR models, first task would be calculate the phase current, please refer to below diagram for Delta configuration. if the source is 380V 3 phase, then Line voltage equals to phase voltage at 380V. suppose you have a heating system with 30KW in total, each phase would be with 10KW, the phase voltage is 380V, the phase current = Power / Voltage

$$\text{So phase current} = \frac{10,000W}{380V} = 26.3 \text{ Amps}$$

For a 30KW heater in Delta configuration with source at 380V, the phase current is 26.3 amps, the SCR rating should be twice as much as the actual phase current so the SCR rating should be 26.3\*2 which is 52.6 amps, according to the ordering information, the SCR should be 60 amps. based on the input, such as 4-20mA the ordering code for this application should be SCR-51-3628-NN

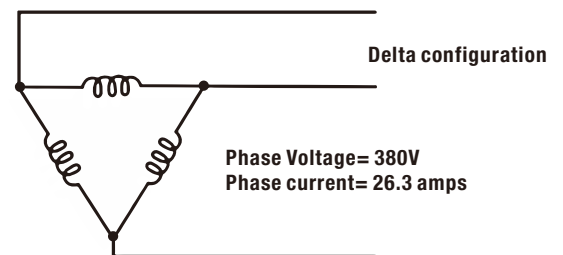

Example 2: in a Star configuration application, suppose the source is 380V, and total power of heater is 30KW, each phase would be 10KW, the phase voltage will be 380 / 1.732, the phase voltage is 219V

$$\text{So phase current} = \frac{10,000W}{219V} = 45.6 \text{ Amps}$$

By apply the same principle, the rating of the SCR should be twice as much as the actual load, the rating of the SCR should be 91.2 amps, if the input is 0-10Vdc, the item number of the correct SCR should be SCR-51-3126-NN

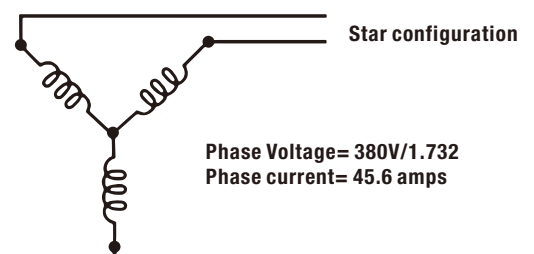

## Panel description

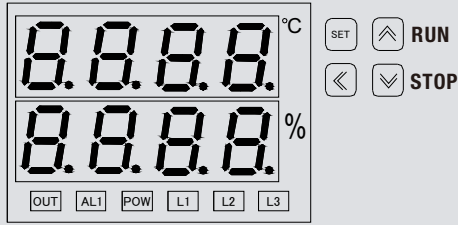

**INDICATOR**

- OUT:** The flashing frequency indicate the output ratio
- AL1:** Over temperature alarm indicator
- POW:** Power feed indicator
- L1:** Phase indicator, when L1 absence, lights on
- L2:** Phase indicator, when L2 absence, lights on
- L3:** Phase indicator, when L3 absence, lights on

**SET KEY**

- SET:** Parameter setting and configuraion
- POW:** Power feed indicator
- : Left shift key, to shift the display unit
- : Decrease key or press it more than 3 seconds to stop the operation of the SCR
- : Increase key or press it more than 3 seconds to run the SCR after stop

## Size and dimension

**40 and 60 and 75 amps(same size)**

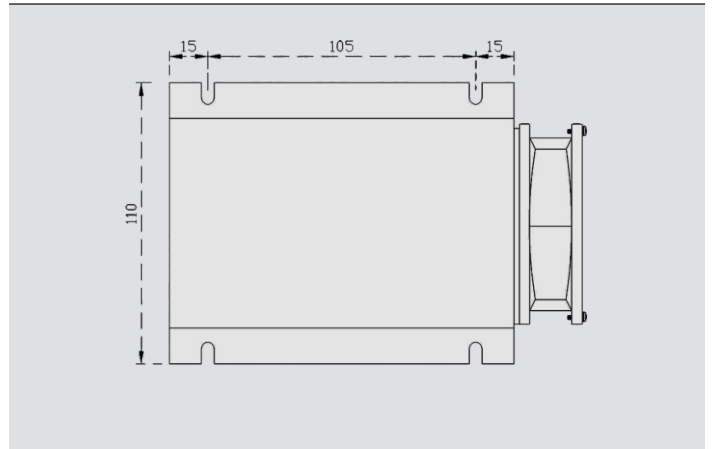
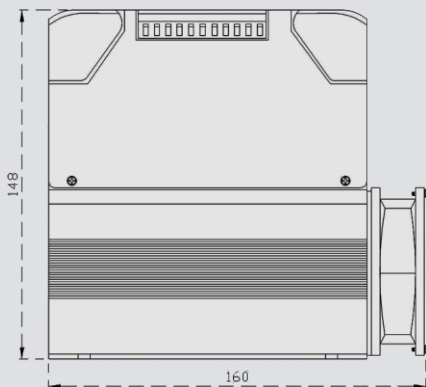

## Wiring diagram(Input and load)

### Load

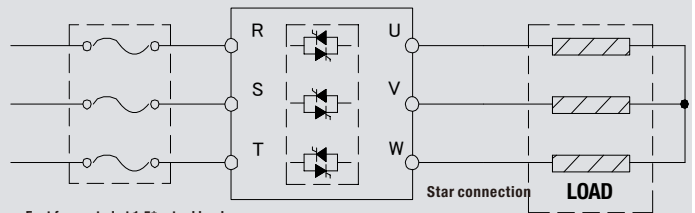

Fast fuse rated at 1.5\*actual load  
for example, if the acutal current is 20 amps  
then fast fuse should be 30 amps

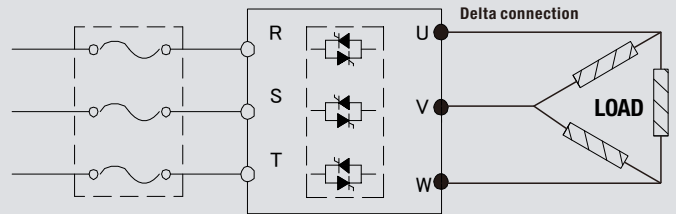

## Power Regulator

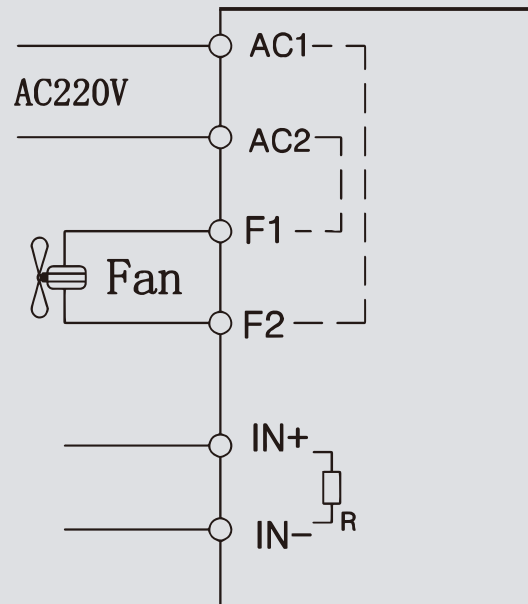

**AC1 and AC 2** for power supply  
**F1 and F2** is the source for cooling fans  
**IN+ and IN-** is for input signal, such as 4-20mA, 0-10Vdc

## Panel discription

### Power on



Press SET once to enter into configuration menu

**UAd** UAD: each SCR has an address if it comes with RS-485 function the communication address of specific SCR will be assigned to this parameter, for example, if the lower shows "1" then this is number 1 device

**LcH** LCK  
SET LCK=101 to enter into configuration menu 1

**AL1** AL1  
SCR temperature higher limit alarm, the maximum allowable temperature will be assigned to this parameter, for example, you can put 80°C as the higher limit, the AL1 alarm will be triggered if the temperature cross AL1 value, and the output of the SCR will be restrained to EOP value

**EoP** EOP  
when AL1 triggered, the SCR output will be constrained to a certain value to protect the SCR, the output value will be assigned to EOP value for example, EOP=25%, when AL1 triggered, the output goes down to 25% immediately

**oPL** OPL  
Minimum output, the output will be higher than OPL value regardless of the input

**oPH** OPH  
Maximum output, the output will be lower than OPH value regardless of the input

**bUF** BUF  
Soft-start, range: 0.0~100.0  
if BUF=0, means it takes 10 seconds for the SCR output changes from OPL-OPH, if BUF=100, soft-start function disabled

**AdD** ADD  
Not functional on SCR-51

**bAU** BAU  
Not functional on SCR-51

**UAd** Not functional on SCR-51

**LcH** LCK  
Set LCK=202 to menu 2

**AUto** AUto  
Not functional on SCR-51

**rUN** rUN  
Run/stop function configuration  
0: run/stop function disabled  
1: run/stop function enabled

**H=** Hz  
Choose the frequency based on your power  
50H: for 50HZ  
60H: for 60HZ

## Input VS load table

### SCR-6-3428-NN

Input (mA)	Last (W) 5000	Last (W) 5000	Last (W) 2500	Last (W) 2500
	Load Voltage (VAC)	Output load (%)	Load Voltage (VAC)	Output load (%)
1	0,13	0	0,11	0
2	0,13	0	0,11	0
3	0,13	0	0,11	0
4	0,13	0	0,11	0
5	16,8	5,5	13,6	6,4
6	35,2	11,7	35,2	11,6
7	58,2	18	58,1	17,9
8	82,4	24,1	83,2	24
9	108	30,5	109,8	30
10	132	36,6	135,5	36,2
11	158	42,8	159	42,6
12	182	49	180,9	48,8
13	202	55,2	210	55,1
14	219	61,3	335	61
15	235	67,4	352	67,2
16	321	73,6	364	73,5
17	343	80	375	79,7
18	360	86,2	383	85,9
19	372	92,2	386	92,4
20	380	98,5	390	98,4
21	380	100	394	100

Approximate control curve SCR-51 (example 4-20 mA)

