

Incremental 30-mm-Dia. Rotary Encoder

M30SA

Ultra Small, Space saving

General purpose Encoder with External Diameter of 30mm

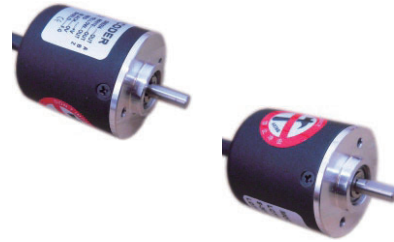

- Incremental model
- External diameter of 30mm
- Resolution up to 1200 ppr.
- Various output type
- Solid shaft with Dia at 4 mm

Ordering Information

M30SA-

Section 1: Basic model name

M30SA: 30mm Rotary Encoder(Mounting Type A)

Section 2: Shaft Size

4: Solid shaft with Dia at 4 mm

Section 3: Resolution

10: 10 ppr
20: 20 ppr

40 50 60 80 100 120 125 150
200 225 240 250 256 300 360 400 450
480 500 512 600 625 720 750 800 900
1000 1024 1080 ...up to 1200

Not indicated resolution is customizable

Section 4: Output phase

3: A B Z
6: A \bar{A} B \bar{B} Z \bar{Z}

Section 5: Output type

T: Push-pull(also known as totem-pull)
N: NPN Open collector
P: PNP Open collector
V: Voltage output
L: Line driver(**Power source 5VDC ONLY,6 phase**)
K: Push-Pull(**With inverted signal,6 phase**)

Section 6: Power Supply

30: 5-30 VDC(+/- 5%)
5: 5 VDC(+/- 5%)

Section 7: Cable outgoing type

E: Rear Entry Cable
Cable Can Only Entry From the Rear
▲Standard cable length is 2M

Ratings and Specifications

- Power supply:** 5 VDC / 8-30 VDC
Resolution: 5-1200 ppr
Current consumption: 100mA(Load disconnected)
Load current: 50mA maximum per channel 20mA maximum per channel (Line driver output)
Output type: NPN/PNP open collector/Complementary/Voltage/Line Driver/Push-Pull(HTL with reverse signal)
Frequency: 100K HZ Frequency=RPM*Resolution/60
Maximum permissible speed: 4000 rpm
Shaft loading radial: 10N
Shaft loading thrust: 20N
Weight: Approx 0.16KG
Protection level: IP50
Temperature: operation(-10°C~+70°C), storage(-30°C~+85°C)
Vibration resistance: 50m/s, 10-65 HZ, 1 mm double amplitude for 2 hours each in X, Y, and Z directions
Shock resistance: 980m/s, 6m/s 2 times each in X, Y, and Z directions
Starting torque: 1 x 10⁻³ N.m Maximum

Output circuits and wave forms

Wave forms

Complementary/Open collector(NPN&PNP)/Voltage output

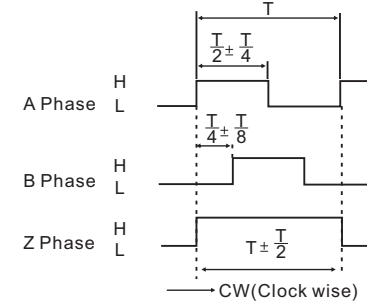

CW: As viewed from the shaft

Line Driver(RS422)/Push-pull(HTL with reverse signal)

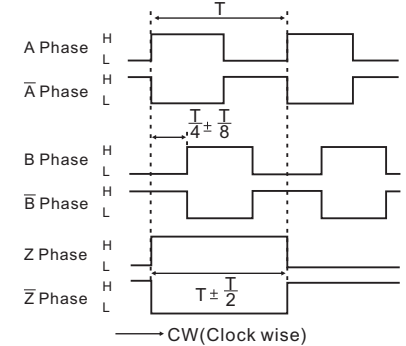

CW(Clock wise)

Output circuits

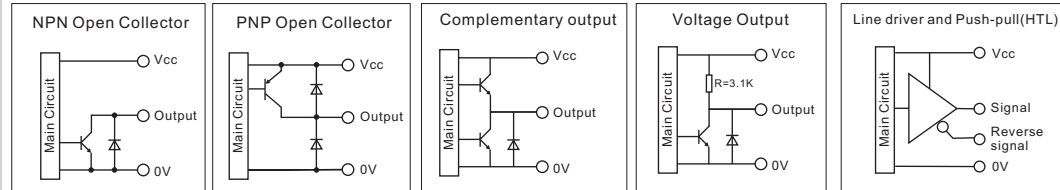

Wiring Details

Complementary/Open collector(NPN/PNP)/Voltage output

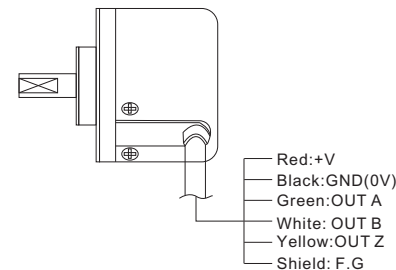

Line Driver/Push-pull(HTL with reverse signal)

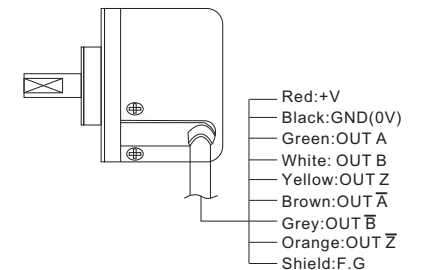

Mounting and Dimensions

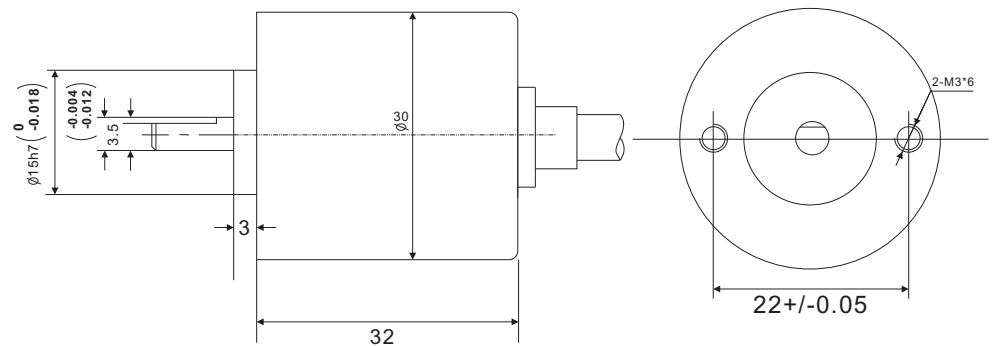

M30SA(Mounting Type A)